

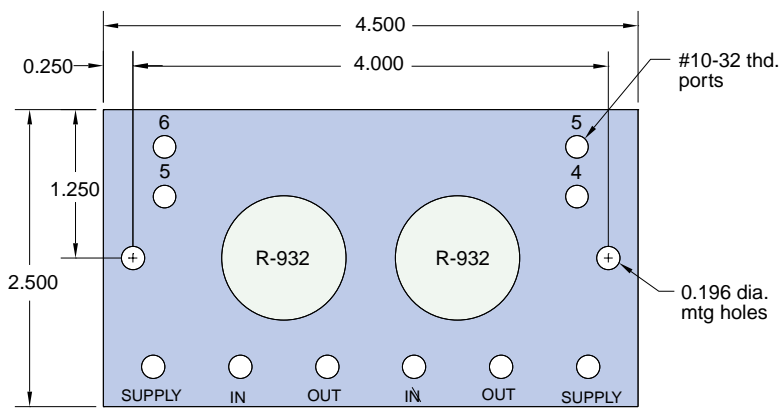

# STANDARD PNEUMATIC CIRCUIT BOARD

## CM-025

Circuit Board for R-932 Sequencing System Using 2 Modular Valves

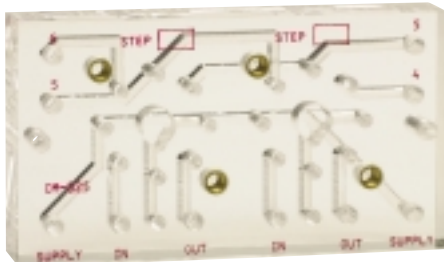

**Size:** 4 1/2" x 2 1/2" x 13/16" thick - 2 modules

**Use:** 2-valve sequence circuit board used as an expansion unit. #10-32 port connections provided for signal inputs, step outputs, supply, and jumper connections for linking multiple boards together. May serve as a final segment of circuit or be inserted between two other sequencing circuit board.

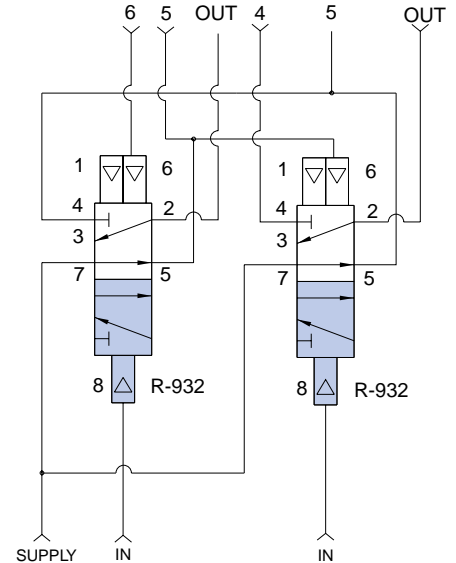

## CM-026

Circuit Board for R-932 Sequencing System Using 3 Modular Valves



**Size:** 6" x 2 1/2" x 13/16" thick - 3 modules

**Use:** 3-valve sequence circuit board used as an expansion unit. #10-32 port connections provided for signal inputs, step outputs, supply and jumper connections for linking multiple boards together. May serve as final segment of circuit or be inserted between two other sequencing subplates.

